



ERIE COUNTY WATER AUTHORITY

INTEROFFICE MEMORANDUM

July 1, 2024

To: Terrence D. McCracken, Secretary to the Authority

From: Michael W. Wymer, PE, Senior Production Engineer *MW*

Subject: Contract GZA-001
Sturgeon Point Water Treatment Plant – Shoreline Stabilization
ECWA Project No. 202200039
Change Order No. 1

Attached is Change Order No. 1 pertaining to the above referenced contract. The change order includes two items.

Modification 001, 18-inch Diameter Drainpipe Rehabilitation, includes the removal of approximately 90 linear feet of existing 18-inch diameter reinforced concrete drain pipe at the shoreline between existing Outfall Chambers S-1 and S-2, including the existing 18-inch diameter tee and elbow at Chamber S-2. During construction, a significant crack/displacement was discovered at the 18-inch diameter tee, resulting in substantial leakage adjacent to the outfall structure. Modification 001 includes the replacement of the 18-inch pipe, tee, and elbow with ductile iron pipe. Pipe joints will be mechanically restrained, providing further stability. Modification shall also include upper slope grading and restoration to match adjoining the work.

Modification 002, Security Allowance Decrease and General Contingency Allowance Increase transfers the \$20,000.00 allowance provided under Bid Item No. 3 Security Allowance to Bid Item No. 4 General Contingency Allowance. The Security Allowance, which was designated for a contractor-supplied guard at the gate, was not utilized under this contract. Transfer of these funds to the General Contingency allowance provides further funds for use in placement of additional armor stone beyond the contract quantity (if needed). This modification results in a net no cost change to the Contract Price.

Modification 003, Completion Time Modification extends the dates for Substantial Completion and Final Payment to September 1, 2024 and October 1, 2024 respectively. These extensions are due to the additional time needed to acquire the materials and construct the replacement of the 18-inch diameter outfall drain line work (described above) and the 42-inch storm drain outfall pipe replacement, paid under the contingency allowance.

Budget Information:

Unit: 2510 Engineering/Construction – Sturgeon Point
2024 Capital Budget Item No.: 101666 Sturgeon Point Shoreline Protection

MWW:jmf
Attachments
cc: L.Kowalski, PE
CONT-GZA-001

ERIE COUNTY WATER AUTHORITY
AUTHORIZATION FORM
For Approval/Execution of Documents
(check which apply)

Contract: GZA-001 **Project No.:** 202200039
Project Description: Sturgeon Point WTP – Shoreline Stabilization

Item Description:







<input type="checkbox"/> Agreement	<input type="checkbox"/> Professional Service Contract	<input type="checkbox"/> Amendment	<input checked="" type="checkbox"/> Change Order
<input type="checkbox"/> BCD	<input type="checkbox"/> NYSDOT Agreement	<input type="checkbox"/> Contract Documents	<input type="checkbox"/> Addendum
<input type="checkbox"/> Recommendation for Award of Contract	<input type="checkbox"/> Recommendation to Reject Bids		
<input type="checkbox"/> Request for Proposals			
<input type="checkbox"/> Other _____			

Action Requested:

<input checked="" type="checkbox"/> Board Authorization to Execute	<input checked="" type="checkbox"/> Legal Approval
<input type="checkbox"/> Board Authorization to Award	<input checked="" type="checkbox"/> Execution by the Chairman
<input type="checkbox"/> Board Authorization to Advertise for Bids	<input type="checkbox"/> Execution by the Secretary to the Authority
<input type="checkbox"/> Board Authorization to Solicit Request for Proposals	
<input type="checkbox"/> Other _____	

Approvals Needed:

APPROVED AS TO CONTENT:

<input checked="" type="checkbox"/> Sr Production Engineer	<u></u>	Date: <u>7/3/2024</u>
<input checked="" type="checkbox"/> Chief Operating Officer	<u></u>	Date: <u>07/03/2024</u>
<input checked="" type="checkbox"/> Executive Engineer	<u></u>	Date: <u>7/3/2024</u>
<input checked="" type="checkbox"/> Director of Administration	<u></u>	Date: <u>07/03/2024</u>
<input checked="" type="checkbox"/> Risk Manager	<u></u>	Date: <u>7/3/2024</u>
<input checked="" type="checkbox"/> Chief Financial Officer	<u></u>	Date: <u>07/03/2024</u>
<input checked="" type="checkbox"/> Legal	<u></u>	Date: <u>7/3/2024</u>

APPROVED FOR BOARD RESOLUTION:

<input checked="" type="checkbox"/> Secretary to the Authority	<u></u>	Date: <u>7/8/2024</u>
--	---	-----------------------

Remarks: Change Order No. 1

Resolution Date: _____ **Item No:** _____

CHANGE ORDER NO. 01

Owner: Erie County Water Authority Owner's Project No.: 202200039
Engineer: GZA GeoEnvironmental of New York Engineer's Project No.: 03.0035028.00
Contractor: Union Concrete and Construction Corp. Contractor's Project No.: 4690
Project: Sturgeon Point Water Treatment Plant Shoreline Stabilization
Contract Name: GZA-001 Shoreline Stabilization
Date Issued: 7/1/2024 Effective Date of Change Order: 7/18/2024

The Contract is modified as follows upon execution of this Change Order:

Description:

This Change Order results in a change in Contract Price and project completion date, as described below with additional information included in the attachments.

- **Modification 001, 18-inch Diameter Outfall Pipe Rehabilitation:** Removal of approximately 90 linear feet of existing 18-inch diameter reinforced concrete drain pipe at the shoreline between existing Outfall Chambers S-1 and S-2, including the existing 18-inch diameter tee and elbow at Chamber S-2, and replacement with 90 linear feet of 18-inch diameter ductile iron pipe. Pipe joints shall be mechanically restrained. Modification shall also include upper slope grading/restoration to match adjoining work. The total cost for this work will increase the project by \$53,379.44.
- **Modification 002, Security Allowance Decrease and General Contingency Allowance Increase:** Decrease of \$20,000.00 to Bid Item No. 3 Security Allowance and increase of \$20,000.00 to Bid Item No. 4 General Contingency Allowance. This modification results in a net no cost change in Contract Price by decreasing the security allowance (services will not be used) and increasing the general contingency allowance accordingly.
- **Modification 003, Completion Time Increases:** Extend the dates for Substantial Completion to September 1, 2024 and the date for Final Payment to October 1, 2024. The extension of these dates is necessary due to the additional work to rehabilitate the 18-inch Outfall Drain Pipe (described above) and to rehabilitate the existing 42-inch storm drain, paid under the contingency allowance.

Attachments:

- Union Concrete Scope and Price Proposal, dated June 4, 2024.
- Union Concrete Time Extension Request, dated July 1, 2024.

EJCDC® C-941, Change Order, Rev. 1

Copyright© 2018 National Society of Professional Engineers, American Council of Engineering Companies and American Society of Civil Engineers. All rights reserved.

CHANGE ORDER NO.: 01

Change in Contract Price	Change in Contract Times
Original Contract Price: \$ 1,220,790.00	Original Contract Times: Substantial Completion: 8/1/2024 Ready for final payment: 10/1/2024
[Increase] [Decrease] from previously approved Change Orders No. N/A to No. N/A: \$ N/A	[Increase] [Decrease] from previously approved Change Orders No. N/A to No. N/A: Substantial Completion: N/A Ready for final payment: N/A
Contract Price prior to this Change Order: \$ 1,220,790.00	Contract Times prior to this Change Order: Substantial Completion: 8/1/2024 Ready for final payment: 10/1/2024
Increase this Change Order: \$ 53,379.44	Increase this Change Order: Substantial Completion: 31 Calendar Days Ready for final payment: 31 Calendar Days
Contract Price incorporating this Change Order: \$ <u>1,274,169.44</u>	Contract Times with all approved Change Orders: Substantial Completion: 9/1/2024 Ready for final payment: <u>11/1/2024</u>

Recommended by Consultant

Accepted by Union Concrete and Construction Corp.

By: Dan Veriotti
 Title: Associate Principal/VP 
 Date: July 3, 2024

By: *Matthew Bliss*
 Title: Vice President
 Date: 7/3/24

Authorized by Owner

By: _____
 Title: _____
 Date: _____

EST. 1950
**UNION
CONCRETE**
CONSTRUCTION

June 4, 2024

Erie County Water Authority
3030 Union Road
Cheektowaga, New York 14227

Attn: Dan Veriotti (GZA)

Re: **Sturgeon Point Water Treatment Plant
Shoreline Stabilization Project
Contract No. GZA-001
Project No. 202200039
Change Order Request #02**

Dear Sir:

As requested, we are providing pricing to replace the existing 18" RCP drain with 18" ductile iron. The pipe is highlighted on the following drawings and connects chamber S-1 and S-2. Our price to perform the work is \$53,379.44. On the following pages you will find backup for the proposed amount.

We trust that this will meet with your approval.

Respectfully,

UNION CONCRETE AND CONSTRUCTION CORP.



Matt Bliss

Matt Bliss

cc: File

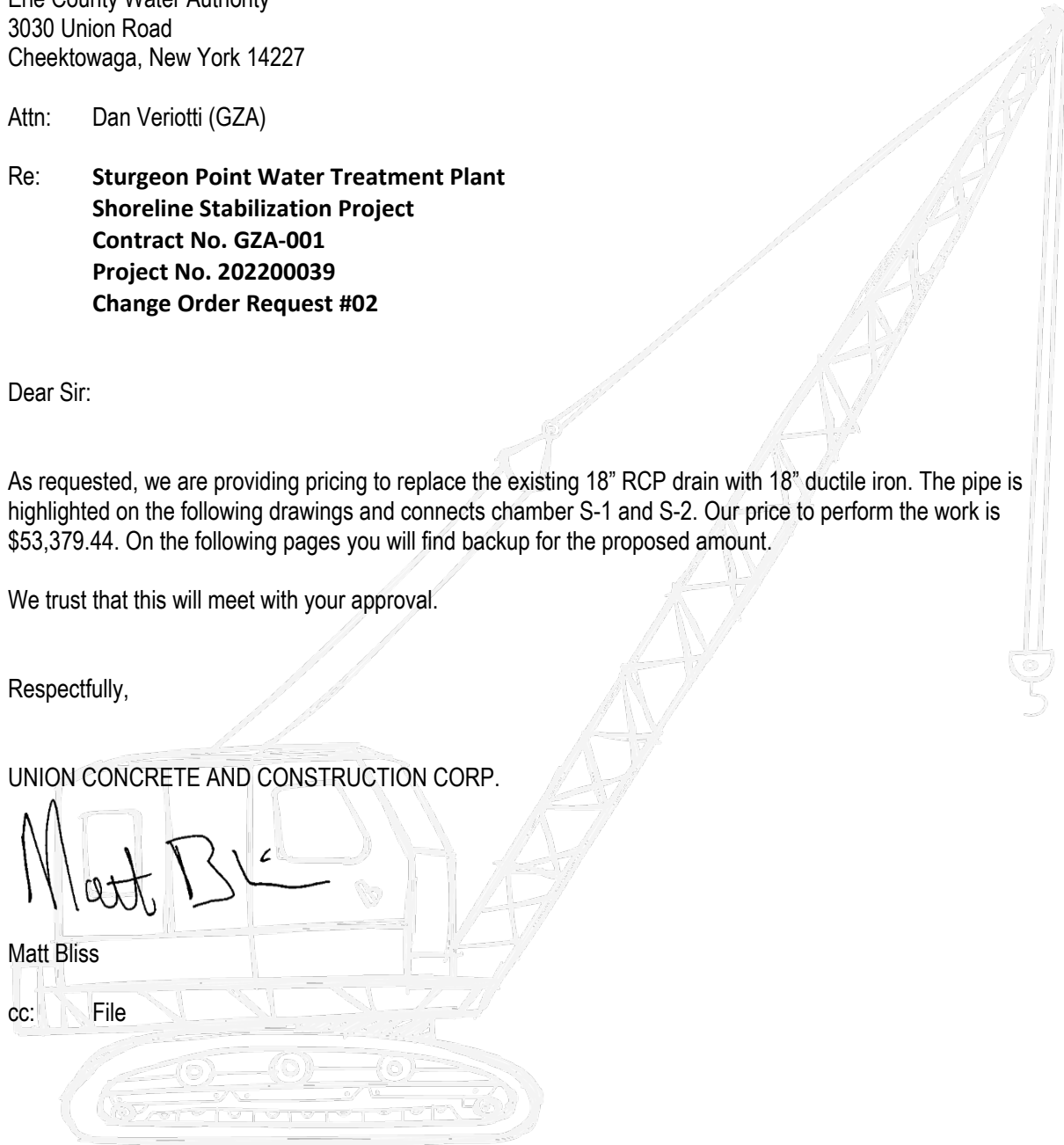

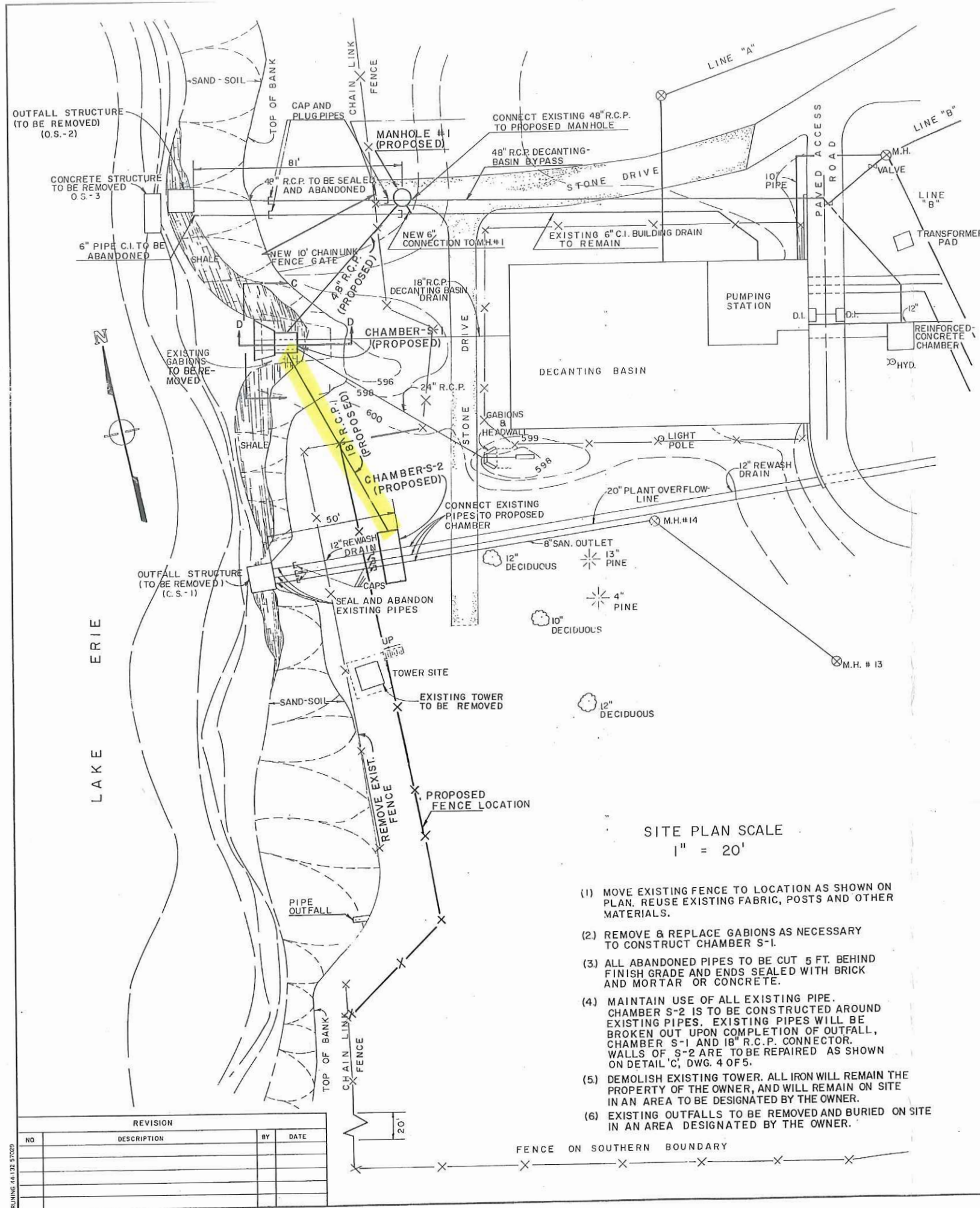

- (1) MOVE EXISTING FENCE TO LOCATION AS SHOWN ON PLAN. REUSE EXISTING FABRIC, POSTS AND OTHER MATERIALS.
- (2) REMOVE & REPLACE GABIONS AS NECESSARY TO CONSTRUCT CHAMBER S-1.
- (3) ALL ABANDONED PIPES TO BE CUT 5 FT. BEHIND FINISH GRADE AND ENDS SEALED WITH BRICK AND MORTAR OR CONCRETE.
- (4) MAINTAIN USE OF ALL EXISTING PIPE. CHAMBER S-2 IS TO BE CONSTRUCTED AROUND EXISTING PIPES. EXISTING PIPES WILL BE BROKEN OUT UPON COMPLETION OF OUTFALL, CHAMBER S-1 AND 18" R.C.P. CONNECTOR. WALLS OF S-2 ARE TO BE REPAIRED AS SHOWN ON DETAIL 'C', DWG. 4 OF 5.
- (5) DEMOLISH EXISTING TOWER. ALL IRON WILL REMAIN THE PROPERTY OF THE OWNER, AND WILL REMAIN ON SITE IN AN AREA TO BE DESIGNATED BY THE OWNER.
- (6) EXISTING OUTFALLS TO BE REMOVED AND BURIED ON SITE IN AN AREA DESIGNATED BY THE OWNER.

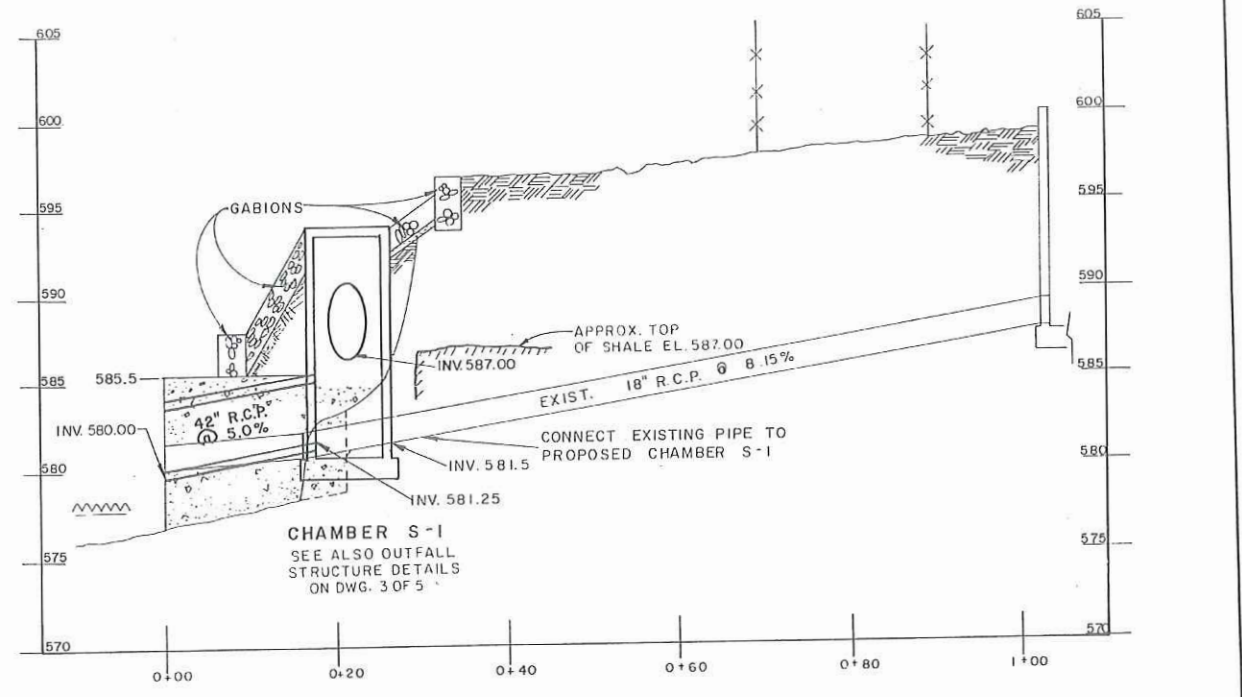

PROFILE — 18" R.C.P. DECANTING BASIN DRAIN AND PROPOSED 42" R.C.P. OUTFALL
SCALE — HORIZ. 1" = 10'
— VERT. 1" = 5'

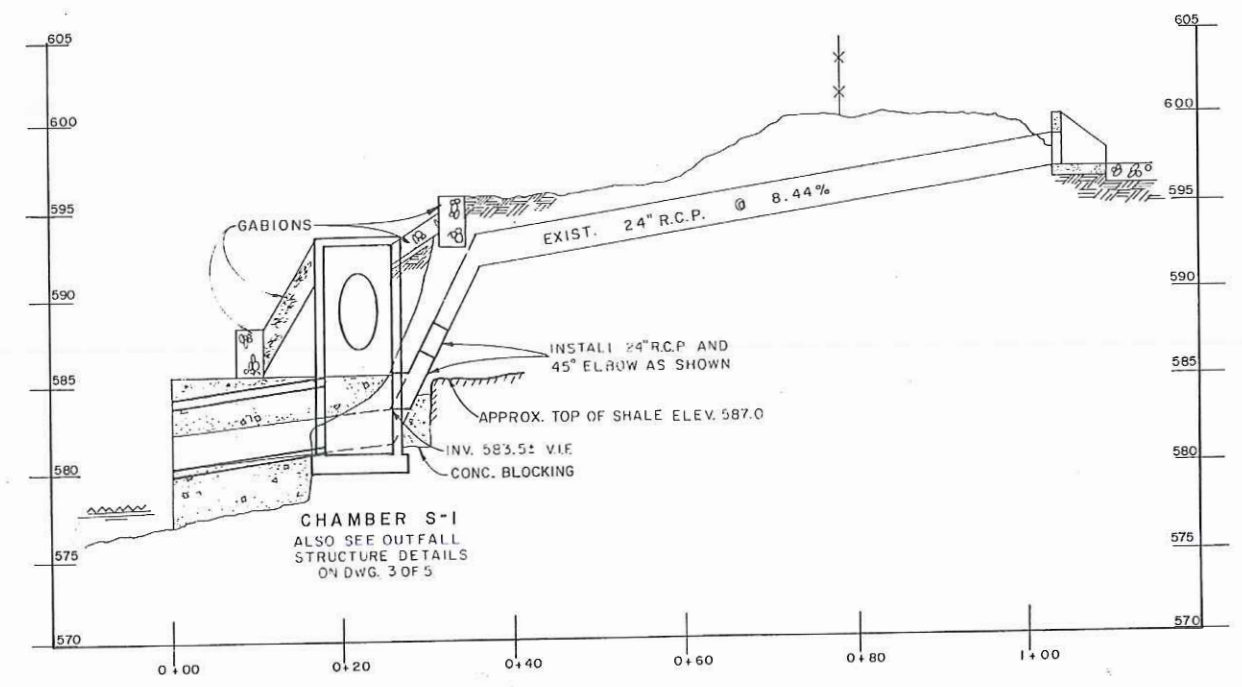

PROFILE — 24" R.C.P. DRAIN
SCALE — HORIZ. 1" = 10'
— VERT. 1" = 5'

OLSON & TERZIAN, P.C.
CONSULTING ENGINEERS URBAN ENGINEERS, INC. BUFFALO, NEW YORK

PARTIAL SITE PLAN & PROFILE

ERIE COUNTY WATER AUTHORITY

SCALE: AS SHOWN
DATE: 7 NOV 1988
DRAWN BY: RNS/N.J.R.
CHECKED BY:
APPROVED:
DRAWING NO.: 2 of 5

CONT-01-003-8801-PD

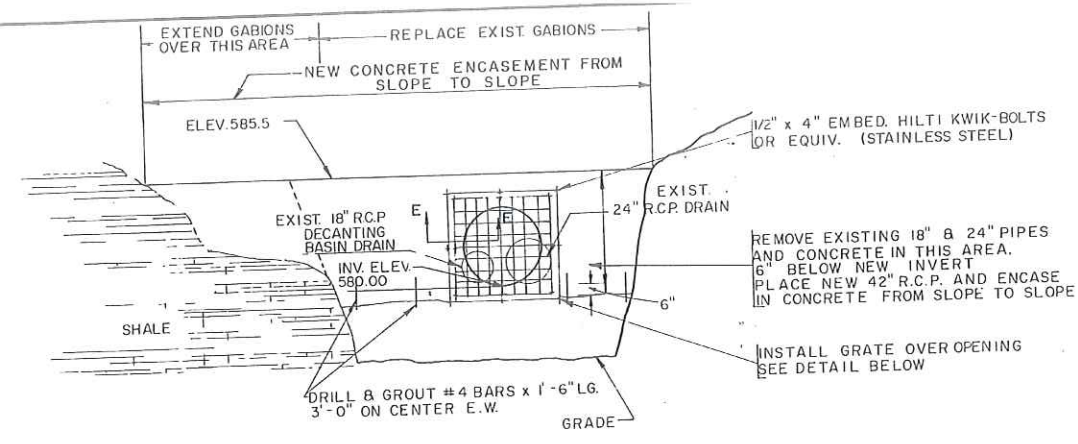

ELEVATION C-C

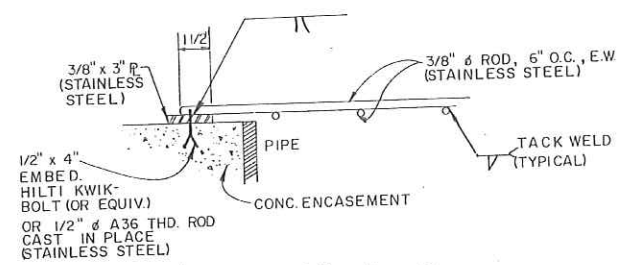

GRATE SECTION E - E
(NOT TO SCALE)

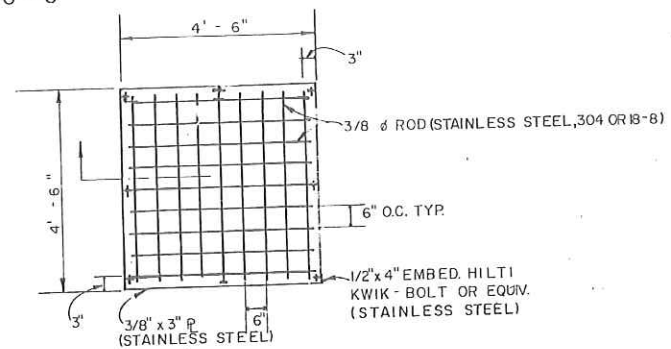

GRATE DETAIL
(SCALE 1/2" = 1')

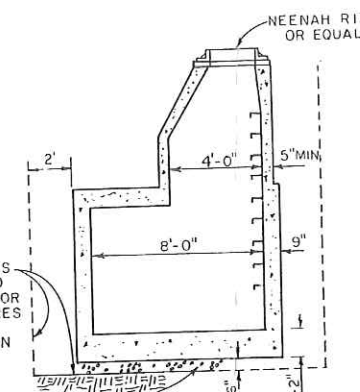

MANHOLE DETAIL
SCALE: 1/4" = 1'-0"

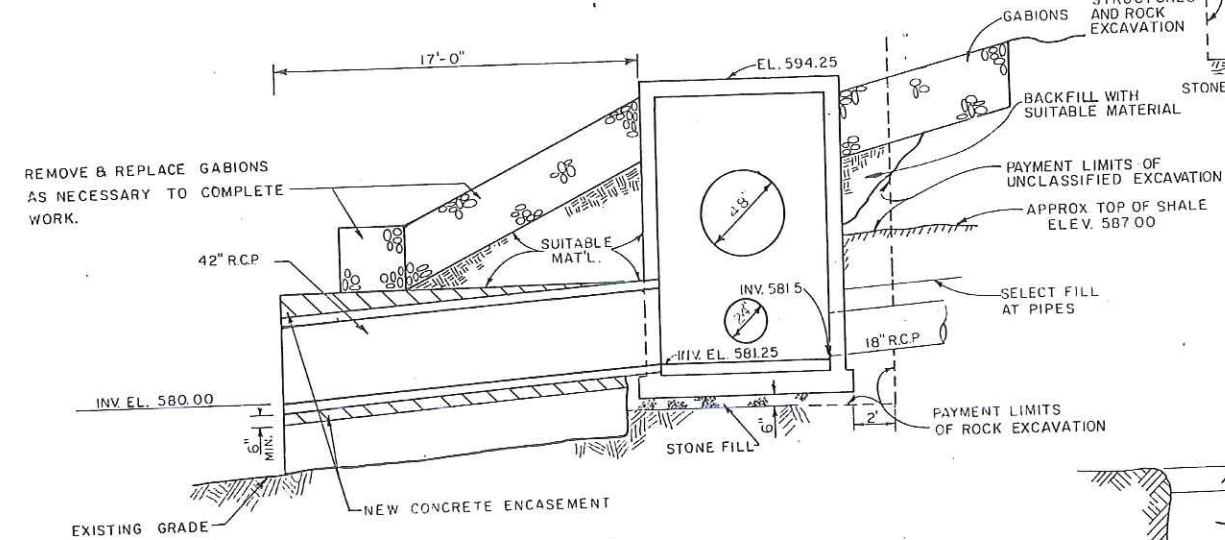

SECTION D-D
(OUTFALL STRUCTURE)
SCALE: 1/4" = 1'

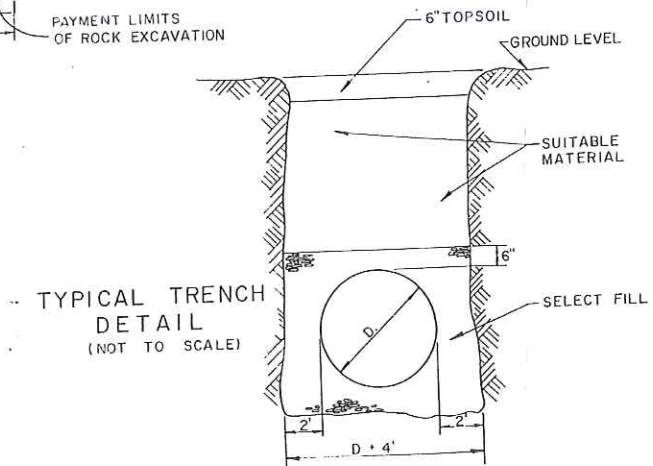

TYPICAL TRENCH
DETAIL
(NOT TO SCALE)

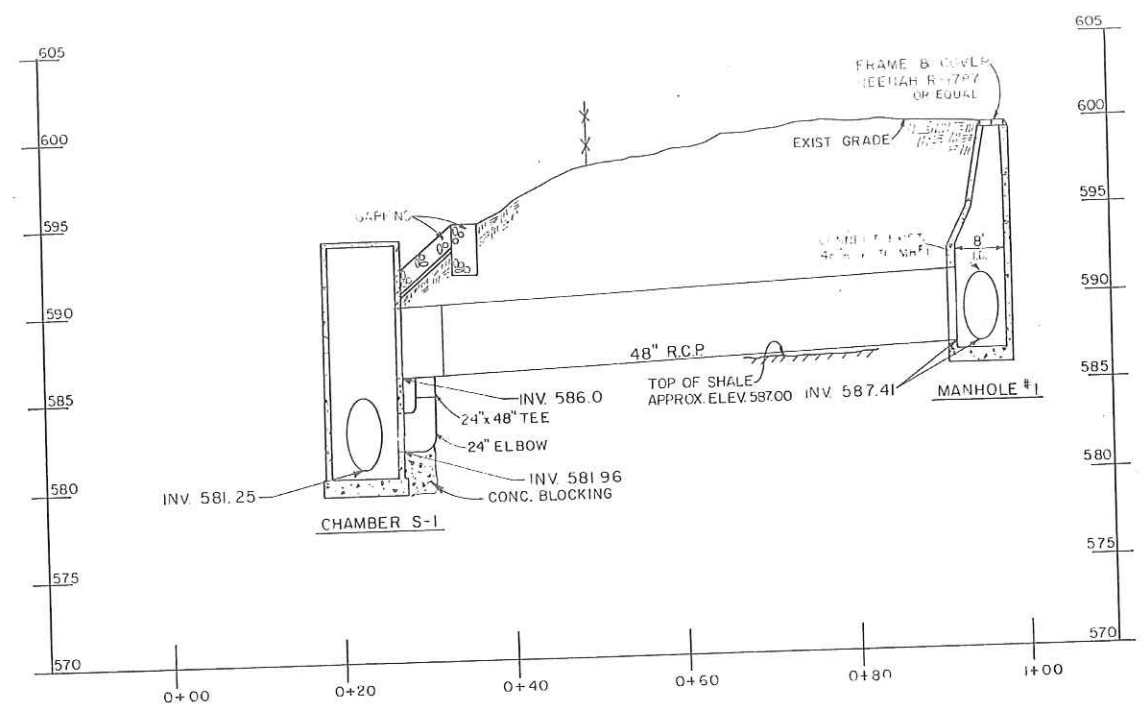

PROFILE — 48" R.C.P. PROPOSED DECANTING BASIN BYPASS
SCALE HORIZ. 1" = 10'
VERT. 1" = 5'

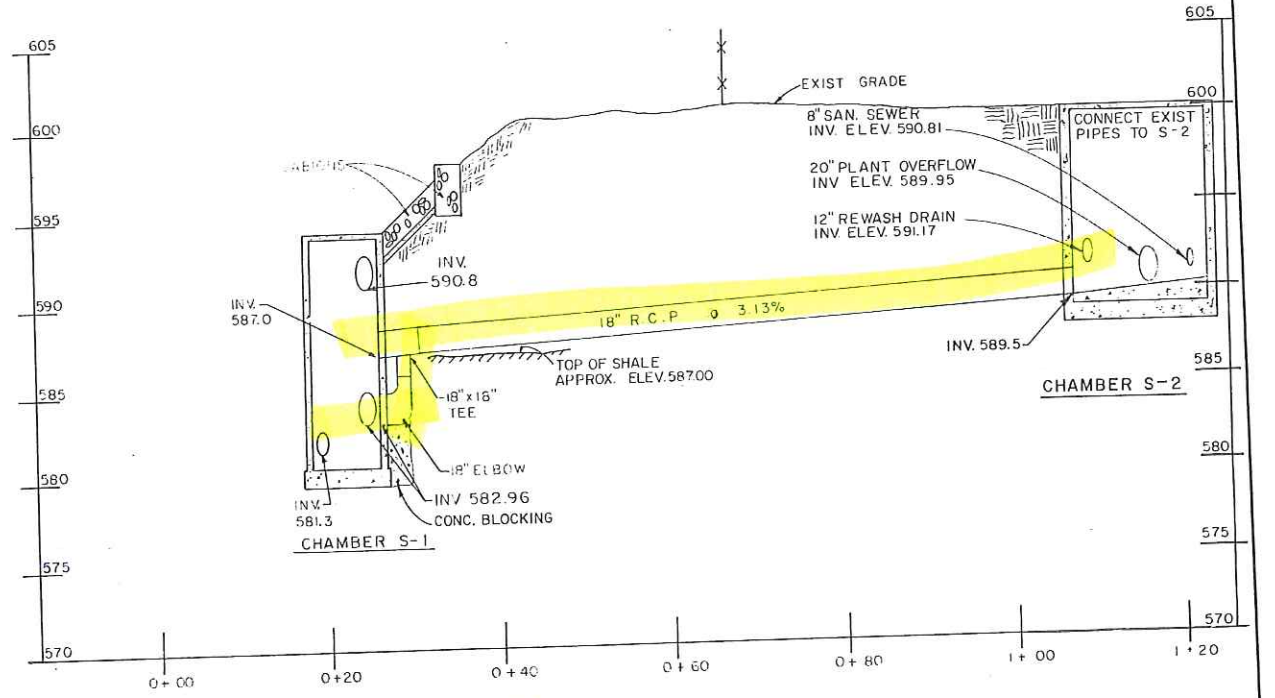

PROFILE — 18" R.C.P. PROPOSED DRAIN
FOR CHAMBER S-2
SCALE — HORIZ. 1" = 10'
VERT. 1" = 5'

REVISION			
NO	DESCRIPTION	BY	DATE

OLSON & TERZIAN, P.C.
URBAN ENGINEERS, INC.
BUFFALO, NEW YORK
CONSULTING ENGINEERS

PROFILES & DETAILS
ERIE COUNTY WATER AUTHORITY

SCALE: AS SHOWN
DATE: NOV. 1988
DRAWN BY: K.N.E./N.J.R.
CHECKED BY:
APPROVED:
DRAWING NO.: 3 of 5

CONT-01-002-8801-PD

NEW YORK STATE DEPARTMENT OF TRANSPORTATION

Agreed Price Worksheet - Prime Contractor

*Use this Form for Projects
let on or after 9/1/2022

Contract: **GZA-001** Item No.: _____ Quantity: **1.00** Units: **LS**

Item Description : **Replace 18" RCP Drain**

(A) LABOR

Trade	Reg Hours	Wage Rate	Cost	Fringe Hours	Fringe Rate	Cost
Laborer FM	32.0	\$ 38.35	\$ 1,227.20	32.0	\$ 28.90	\$ 924.80
Laborer(s)	64.0	\$ 34.86	\$ 2,231.04	64.0	\$ 28.90	\$ 1,849.60
Carpenter FM		\$ 45.77	\$ 0.00		\$ 32.09	\$ 0.00
Carpenter(s)		\$ 38.69	\$ 0.00		\$ 32.09	\$ 0.00
Operator(s)	32.0	\$ 42.64	\$ 1,364.48	32.0	\$ 35.36	\$ 1,131.52
Teamster(s)		\$ 44.48	\$ 0.00		\$ 16.71	\$ 0.00

Wages **\$ 4,822.72**

Fringes **\$ 3,905.92**

If Fringes are paid directly to employee via cash or check, Enter value here:

\$ 0.00

Worker's Compensation Rate (%):

16.79 %

Total of Wages and Fringes: **\$ 8,728.64**

Workers Compensation: **\$ 809.73**

Standard Labor Markup: **\$ 602.84**

Fringe Benefit Markup: **\$ 0.00**

Labor Total: \$10,141.21

(The Contractor shall submit an insurance policy declaration / rate page from its insurer to validate the Workers Comp insurance rate based on an EMR of 1.0.)

(B) MATERIALS

Description	Units	# of Units	Cost/Unit	Cost	Description	Units	# of Units	Cost/Unit	Cost
Pipe & Fittings	LS	1.00	\$18,864.63	\$18,864.63					
Crusher Run	Tn	120.00	\$24.00	\$2,880.00					
Brick & Mortar	LS	1.00	\$400.00	\$400.00					

Materials Total: \$22,144.63

(C) EQUIPMENT

Description	Hours	FHWA Rate	Cost	Description	Hours	FHWA Rate	Cost
PC360	32.0	\$146.13	\$4,676.16				
Haul Truck	32.0	\$240.63	\$7,700.16				
FM Pickup	32.0	\$33.85	\$1,083.20				

Equipment Total: \$13,459.52

(D) SERVICES

Description / Type	# of Units	Cost / Unit	Cost	Description / Type	# of Units	Cost / Unit	Cost

Services Total:

(E) OVERHEAD & PROFIT

	OH & Profit %	Cost
Labor, Materials, & Equipment Total :	\$ 45,745.36	\$ 6,861.80
Services:		\$ 0.00

Overhead & Profit Total: \$ 6,861.80

(F) INSURANCE

Enter rate here if based on payroll

Payroll Based Cost Basis

\$ 0.00

Enter rate here if based on sales

Sales Based Cost Basis

1.47 %

\$ 52,607.17

Insurance Total: \$ 772.27

Item Total: \$ 53,379.44

Unit Price: \$ 53,379.44 per LS

Contractor's Rep Name _____ Signature _____ Date _____ Engineer-in-Charge's Name _____ Signature _____ Date _____



Bid Proposal for ECWA STURGEON POINT DRAIN

UNION CONCRETE & CONSTRUCTION

Job Location: Derby, NY, NY

Bid Date: 05/21/2024

Core & Main 3551949

Core & Main

650 West Ave

Lockport, NY 14094

Phone: 7166258666

Fax: 7164340296

Seq#	Qty	Part Number	Description	Units	Price	Ext Price
10	108 90	011852T	18 TJ CL52 DI PIPE	FT	127.99	13,822.92 \$11,519.10
30	1	96PW202454200	54X200 POLYWRAP BLK 20-24 DIP 8MIL PERF 20' PER ROLL	RL	281.99	281.99
50	1	21I189M	18 MJ 90 C153 IMP	EA	1,061.49	1,061.49
60	1	21I18T180M	18 MJ TEE C153 IMP	EA	1,787.94	1,787.94
80	5	21AMF8181118	18 EBAA MEGALUG MJ DI 1118 RST F/DI PIPE , BLACK	EA	290.50	1,452.50
90	3	21AMF718171800Y	18 DIP BELL JT REST 171800Y W/BLUE FLUORODE RODS	EA	771.52	2,314.56
110	5	21AMG118	18 MJ REGULAR GASKET F/DI	EA	21.01	105.05
120	60	21AMB10745CTBAIS	3/4X4-1/2 T-HEAD B&N CORBLUE AIS COMPLIANT	EA	5.70	342.00
					Sub Total	21,168.45
					Tax	0.00
					Total	21,168.45 \$18,864.63

UNLESS OTHERWISE SPECIFIED HEREIN, PRICES QUOTED ARE VALID IF ACCEPTED BY CUSTOMER AND PRODUCTS ARE RELEASED BY CUSTOMER FOR MANUFACTURE WITHIN THIRTY (30) CALENDAR DAYS FROM THE DATE OF THIS QUOTATION. CORE & MAIN LP RESERVES THE RIGHT TO INCREASE PRICES TO ADDRESS FACTORS, INCLUDING BUT NOT LIMITED TO, GOVERNMENT REGULATIONS, TARIFFS, TRANSPORTATION, FUEL AND RAW MATERIAL COSTS. DELIVERY WILL COMMENCE BASED UPON MANUFACTURER LEAD TIMES. ANY MATERIAL DELIVERIES DELAYED BEYOND MANUFACTURER LEAD TIMES MAY BE SUBJECT TO PRICE INCREASES AND/OR APPLICABLE STORAGE FEES. THIS BID PROPOSAL IS CONTINGENT UPON BUYER'S ACCEPTANCE OF SELLER'S TERMS AND CONDITIONS OF SALE, AS MODIFIED FROM TIME TO TIME, WHICH CAN BE FOUND AT: <https://coreandmain.com/TandC/>

COUNTY LINE STONE

Tel: (716)-542-5435 • 4515 Crittenden Rd • Akron, NY, 14001 • Fax: (716)-542-5442

SALES QUOTATION

Customer:

December 8, 2023

UCC

Attn: Nick
Phone:
Fax:
Email:

Project: ECWA - Sturgeon Point 2024
Bid Date: 12/8/2023
Quote Exp. Date: 3/30/2024
Sales Rep: Brad Buyers
Contact Phone: 716-544-2079
Purchase Order #:

Tax Exempt
Yes / No

Terms:
Net 20 Days from invoice, interest of 1.5% charged after due date

Bonded
Yes / No

Escalator
Yes / No

Esc. Value

ALL PRICES ARE QUOTED BY THE TRUCKLOAD IN U.S TONS UNLESS OTHERWISE NOTED

Product	Est. Quantity	Material Rate	NPW Trailer Haul	PW Trailer Haul
Crusher Run 2"		\$ 12.00	\$12.00	\$ 13.00
#3&4 Stone - 2-4" Limestone		\$ 17.00	\$12.00	\$ 13.00
#3A Stone		\$ 17.00	\$12.00	\$ 13.00
2-3 Ton Armor Stone - Limestone		\$ 50.00	\$16.00	\$ 17.50
1-1.5 Ton Armor Stone - Limestone		\$ 50.00	\$16.00	\$ 17.50
Filter Stone - As Specified		NO BID		
Filter Stone Alt - 150 - 800lb (5% above and below tolerance)		\$ 45.00	\$15.00	\$ 16.00
Filter Stone Alt - Gabion Stone (NYS DOT 620.03, 6-12")		\$ 20.00	\$14.00	\$ 15.00
Filter Stone Alt - Large Gabion (8-16")		\$ 22.00	\$14.00	\$ 15.00
Gabions for Gabion Baskets (as specified)		NO BID		
Gabions Alt for Gabion Baskets (Standard Gabion, 620.03)		\$ 20.00	\$14.00	\$ 15.00
Gabions Alt for Gabion Baskets (8-16" Larger Gabion)		\$ 22.00	\$14.00	\$ 15.00

MATERIAL NOTE: Limestone will have chert nodules and seams, selective quarrying to occur, however no guarantee to meet specs

Note: Pricing as quoted valid through 2024

Fuel Pricing Note: All pricing assumes posted AAA WNY Diesel Fuel Pricing below \$5.50. Otherwise rates null and void.

Hauling Note: waiting time charged to customer after 10 min on the job site @ \$130/hr (tri-axle) & \$160/hr (trailer)

NOTE: If project is tax exempt, please submit exemption form prior to commencement.

ACCEPTANCE

Customer Signature: _____

Date: _____



250 Grider St, Buffalo, NY 14215
 Phone: 716.332.2800 - Fax: 716.332.2803

Page: 1
 Ticket #: 688938-01
 Ticket date: 5/17/24
 Station: 2
 Ori ord #: 688938

Invoice

Sold to:

Union Concrete and Construction
 435 Meyer Rd
 PO Box 410
 West Seneca, NY 14224

Ship to:

1840 Transit Transit Road Bridge
 716-572-8476 Garret

CUSTOMER: UNIONC **SHIP DATE:** 05/16/2024 **TERMS:** Net due in 30 **P.O.:**
SALES REP: KPB **SHIP VIA:** BCA **TRACKING#:** **JOB:**
CC :

QUANTITY	ITEM #	DESCRIPTION	PRICE	UNIT	AMOUNT	TAX
42	Q11028	Quikrete 1136 Mason Mix (S)-80	8.75	EACH	367.50	N
800	CB001	Concrete Brick DOT	1.10	EACH	880.00	N
1	Q0001	Quikrete-Refundable Pallet Charge	30.00	EACH	30.00	N

User: BEV	Total line items: 3	Sale subtotal:	1,277.500
		Tax:	0.00
		Total:	1,277.500
Tender:			
	Accounts Receivable		1,277.50
		Net tender:	1,277.50

Order # 688938
 Order total 0.00
 Order amt due 0.00

NOTES:

Adjustments for E-113 in All Saved Models

Komatsu PC360LC-11
Crawler Mounted Hydraulic Excavators



Size Class:
33.5 - 40.4 mt
Weight:
N/A

Configuration for PC360LC-11

Horsepower **257.0 hp** Operating Weight **78645 lbs**
Power Mode **Diesel**

Blue Book Rates

** FHWA Rate is equal to the monthly ownership cost divided by 176 plus the hourly estimated operating cost.

	Ownership Costs				Estimated Operating Costs Hourly	FHWA Rate** Hourly
	Monthly	Weekly	Daily	Hourly		
Published Rates	USD \$16,560.00	USD \$4,635.00	USD \$1,160.00	USD \$175.00	USD \$52.04	USD \$146.13
Adjustments						
Region (New York: 104%)	USD \$662.40	USD \$185.40	USD \$46.40	USD \$7.00		
Model Year (2023: 99.97%)	(USD \$5.53)	(USD \$1.55)	(USD \$0.39)	(USD \$0.06)		
Adjusted Hourly Ownership Cost (100%)	-	-	-	-		
Hourly Operating Cost (100%)					-	
Total:	USD \$17,216.87	USD \$4,818.85	USD \$1,206.01	USD \$181.94	USD \$52.04	USD \$149.86

Non-Active Use Rates

Standby Rate **Hourly** USD \$59.67
Idling Rate USD \$117.49

Rate Element Allocation

Element	Percentage	Value
Depreciation (ownership)	33%	USD \$5,464.80/mo
Overhaul (ownership)	39%	USD \$6,458.40/mo
CFC (ownership)	17%	USD \$2,815.20/mo
Indirect (ownership)	11%	USD \$1,821.60/mo
Fuel (operating) @ USD 4.03	37.8%	USD \$19.67/hr

Revised Date: 2nd quarter 2024

These are the most accurate rates for the selected Revision Date(s). However, due to more frequent online updates, these rates may not match Rental Rate Blue Book® Print. Visit the Cost Recovery Product Guide on our Help page for more information.

The equipment represented in this report has been exclusively prepared for Shannon Luce (sluce@unionconcretecorp.com)

Adjustments for U-13 in All Saved Models

April 29, 2024

Volvo A40G

Articulated Rear Dumps



Size Class:

34.5 mt & Over

Weight:

N/A
Configuration for A40G

Axle Configuration	6 X 6	Horsepower	472.0 hp
Power Mode	Diesel	Rated Payload	42.99 t

Blue Book Rates

** FHWA Rate is equal to the monthly ownership cost divided by 176 plus the hourly estimated operating cost.

	Ownership Costs				Estimated Operating Costs Hourly	FHWA Rate** Hourly
	Monthly	Weekly	Daily	Hourly		
Published Rates	USD \$26,960.00	USD \$7,550.00	USD \$1,890.00	USD \$285.00	USD \$87.45	USD \$240.63
Adjustments						
Region (New York: 104.3%)	USD \$1,159.28	USD \$324.65	USD \$81.27	USD \$12.26		
Model Year (2017: 98.26%)	(USD \$489.13)	(USD \$136.98)	(USD \$34.29)	(USD \$5.17)		
Adjusted Hourly Ownership Cost (100%)	-	-	-	-		
Hourly Operating Cost (100%)					-	
Total:	USD \$27,630.15	USD \$7,737.67	USD \$1,936.98	USD \$292.08	USD \$87.45	USD \$244.44

Non-Active Use Rates

Standby Rate	Hourly	USD \$91.05
Idling Rate	Hourly	USD \$190.88

Rate Element Allocation

Element	Percentage	Value
Depreciation (ownership)	33%	USD \$8,896.80/mo
Overhaul (ownership)	42%	USD \$11,323.20/mo
CFC (ownership)	14%	USD \$3,774.40/mo
Indirect (ownership)	11%	USD \$2,965.60/mo
Fuel (operating) @ USD 4.03	38.75%	USD \$33.89/hr

Revised Date: 2nd quarter 2024

These are the most accurate rates for the selected Revision Date(s). However, due to more frequent online updates, these rates may not match Rental Rate Blue Book® Print. Visit the Cost Recovery Product Guide on our Help page for more information.

The equipment represented in this report has been exclusively prepared for Shannon Luce (sluce@unionconcretecorp.com)

Adjustments for V-247 in All Saved Models

May 31, 2024

Ford F-250

On-Highway Light Duty Trucks

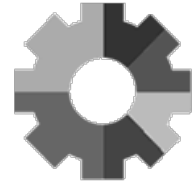
 Size Class:
300 hp & Over
 Weight:
 N/A

Configuration for F-250

Axle Configuration	4.0 X 4.0	Cab Type	Crew
Horsepower	385.0 hp	Power Mode	Gasoline
Ton Rating	3.0 / 4.0		

Blue Book Rates

** FHWA Rate is equal to the monthly ownership cost divided by 176 plus the hourly estimated operating cost.

	Ownership Costs				Estimated Operating Costs Hourly	FHWA Rate** Hourly
	Monthly	Weekly	Daily	Hourly		
Published Rates	USD \$670.00	USD \$190.00	USD \$48.00	USD \$7.00	USD \$30.04	USD \$33.85
Adjustments						
Region (New York: 102.5%)	USD \$16.75	USD \$4.75	USD \$1.20	USD \$0.17		
Model Year (2020: 99.79%)	(USD \$1.47)	(USD \$0.42)	(USD \$0.10)	(USD \$0.02)		
Adjusted Hourly Ownership Cost (100%)	-	-	-	-		
Hourly Operating Cost (100%)					-	
Total:	USD \$685.28	USD \$194.33	USD \$49.10	USD \$7.16	USD \$30.04	USD \$33.93

Non-Active Use Rates

Standby Rate	Hourly USD \$2.57
Idling Rate	USD \$29.15

Rate Element Allocation

Element	Percentage	Value
Depreciation (ownership)	35%	USD \$234.50/mo
Overhaul (ownership)	34%	USD \$227.80/mo
CFC (ownership)	13%	USD \$87.10/mo
Indirect (ownership)	18%	USD \$120.60/mo
Fuel (operating) @ USD 3.45	84.09%	USD \$25.26/hr

Revised Date: 2nd quarter 2024

These are the most accurate rates for the selected Revision Date(s). However, due to more frequent online updates, these rates may not match Rental Rate Blue Book® Print. Visit the Cost Recovery Product Guide on our Help page for more information.

The equipment represented in this report has been exclusively prepared for Shannon Luce (sluce@unionconcretecorp.com)



Gallagher

Insurance | Risk Management | Consulting

July 1, 2023

Union Concrete and Construction Corp.
Nick Osinski
435 Meyer Road P.O. Box 410
West Seneca, NY 14224

Re: Confirmation of GL & WC Rates

Per your request, this letter serves as confirmation of the rates for the General Liability and Workers Compensations for the policy term 07/01/2023 to 07/01/2024 as follows:

General Liability & Umbrella/Excess - \$14.68 per \$1,000 of Sales
Workers Compensation 5506 - \$16.79 per \$100 of Payroll based on an Experience Modification Rate (EMR) of 1.0.

Any questions, please do not hesitate to give me a call.

Sincerely,

Andrew Bizjak
443-541-0166
Client Service Executive

Legal Disclosure

©2018 Arthur J. Gallagher & Co. All rights reserved

EST. 1950
**UNION
CONCRETE**
CONSTRUCTION

July 1, 2024

Erie County Water Authority
3030 Union Road
Cheektowaga, New York 14227

Attn: Dan Veriotti (GZA)

Re: **Sturgeon Point Water Treatment Plant
Shoreline Stabilization Project
Contract No. GZA-001
Project No. 202200039
Change Order Request #06**

Dear Sir:

As discussed, there has been a considerable amount of work added to the above-mentioned contract. Added work includes additional headwall repairs, replacement of 18" drain pipe, and repairing a 42" drain pipe. In addition to the work, the 18" drain pipe materials had a lengthy lead time because ductile iron was requested and 18" ductile is an uncommon size. Due to these factors which were out of our control, we are requesting that the date of substantial completion is extended to September 1, 2024.

We trust that this will meet with your approval.

Respectfully,

UNION CONCRETE AND CONSTRUCTION CORP.



Matt Bliss

Matt Bliss

cc: File